

WARNING
BEWARE OF UNDERGROUND SERVICES
THE LOCATIONS OF UNDERGROUND SERVICES ARE APPROXIMATE ONLY AND THEIR EXACT POSITION SHOULD BE PROVEN ON SITE. NO GUARANTEE IS GIVEN THAT ALL EXISTING SERVICES ARE SHOWN.

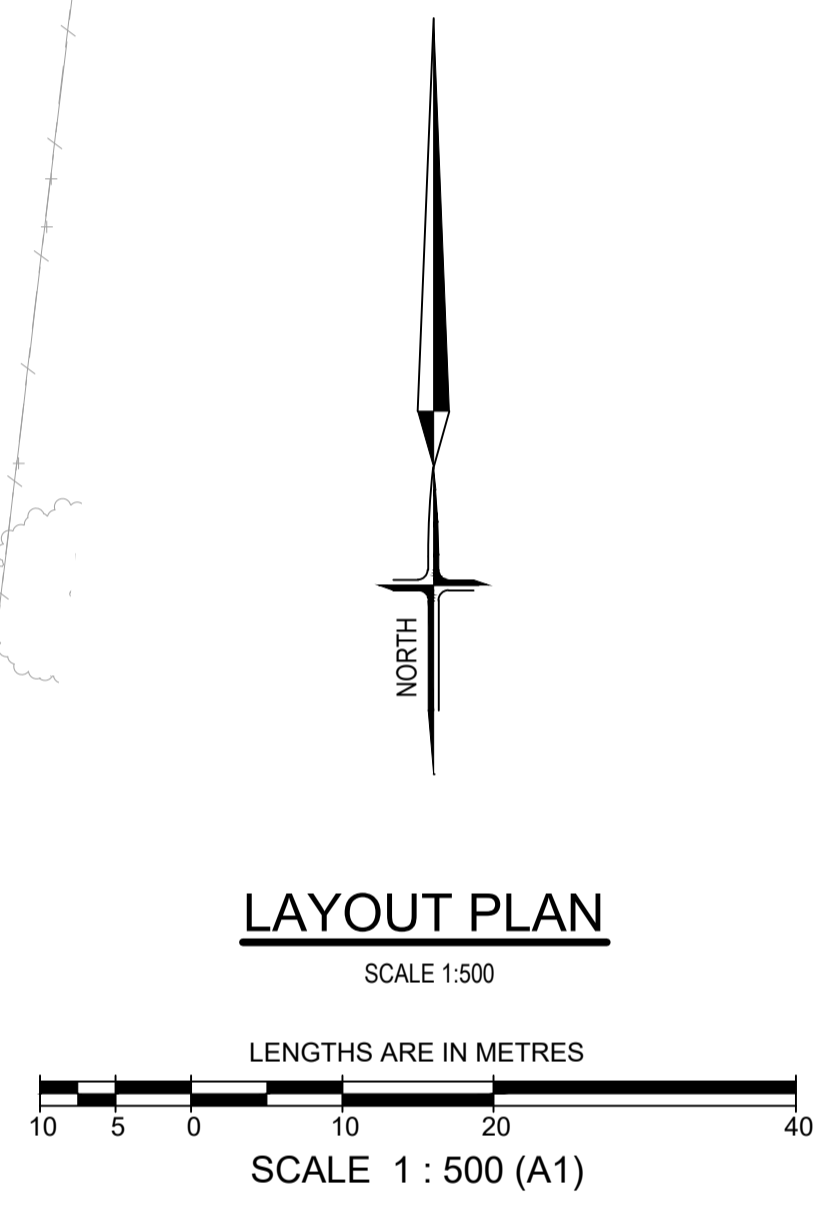
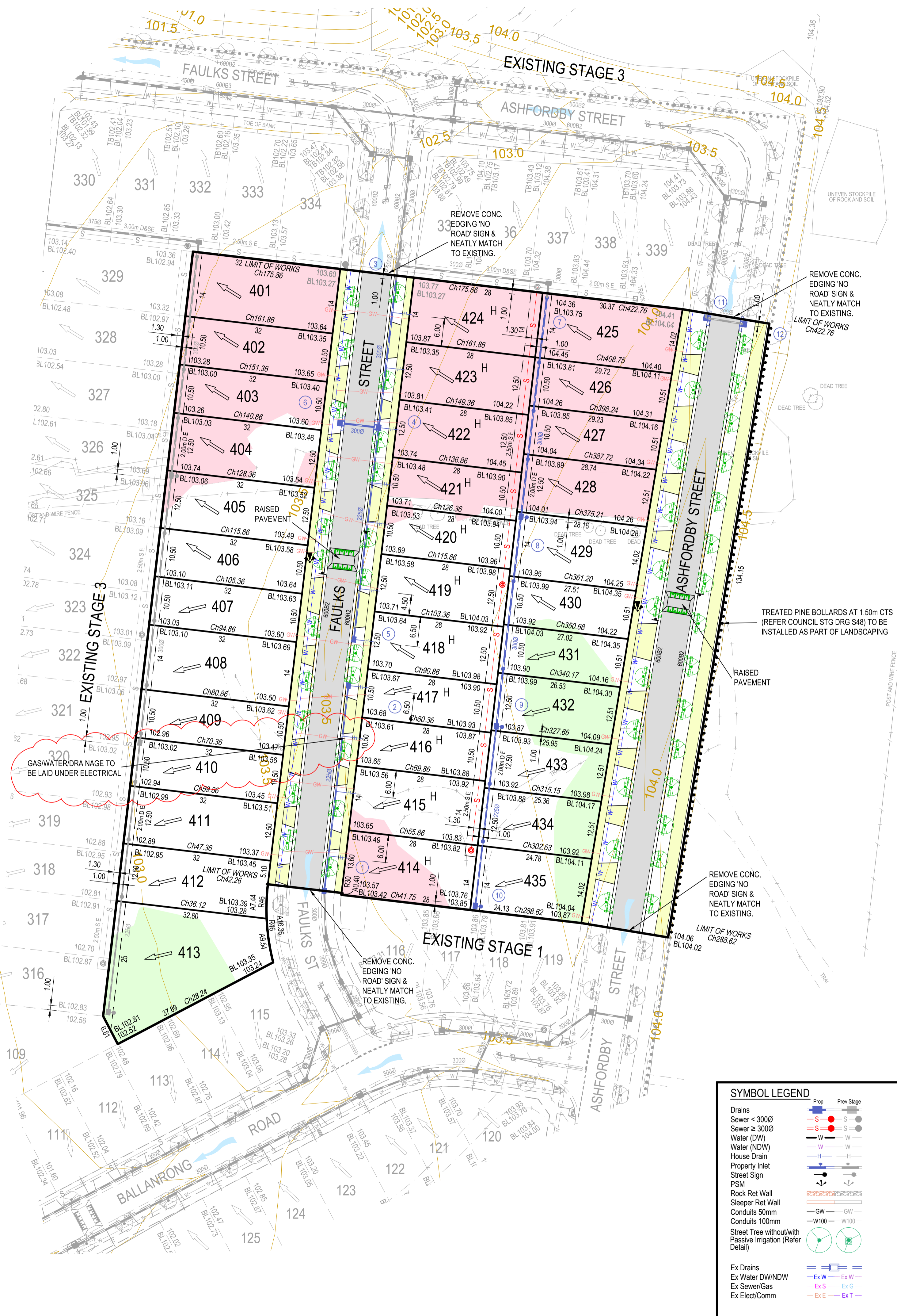
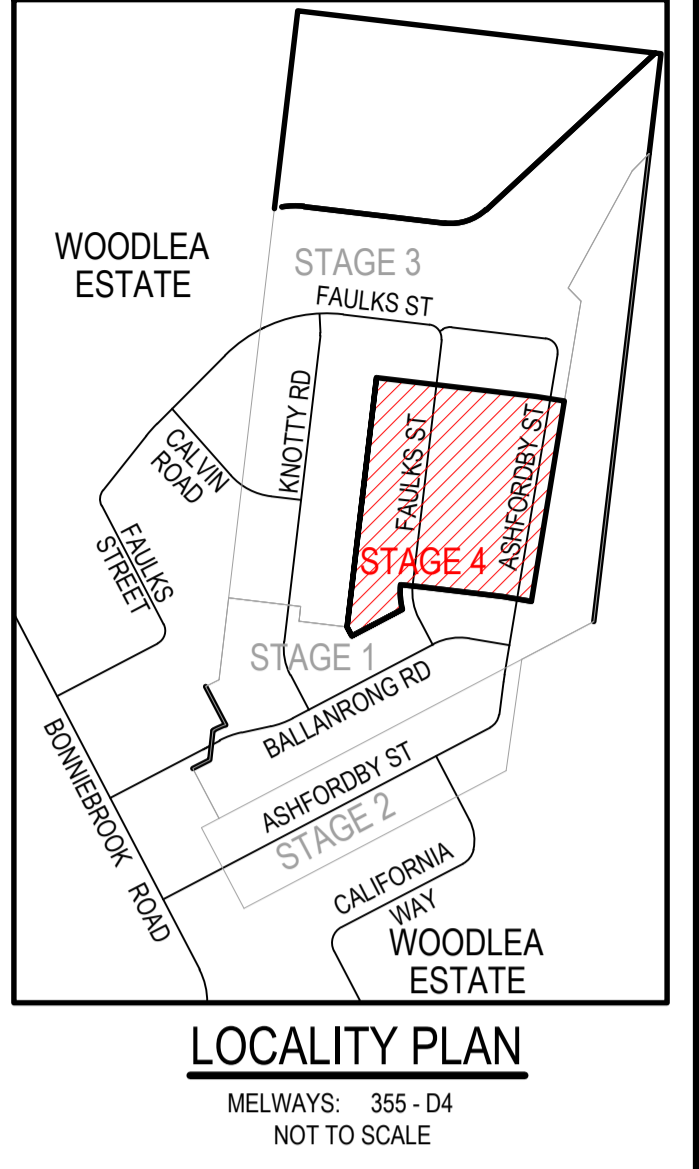

DRAWING INDEX		
Sheet No.	Version	Description
1	F	LAYOUT PLAN & SERVICE OFFSETS TABLE
2	A	GENERAL NOTES, PAVEMENT COMPOSITIONS & TYPICAL CROSS SECTIONS
3	A	ROAD LONGITUDINAL SECTION & CROSS SECTIONS - FAULKS STREET
4	A	ROAD CROSS SECTIONS - FAULKS STREET
5	A	ROAD LONGITUDINAL SECTION - ASHFORDBY STREET
6	A	ROAD CROSS SECTIONS - ASHFORDBY STREET
7	A	DRAINAGE LONGITUDINAL SECTIONS & PIT SCHEDULE
8	A	SIGNAGE & LINEMARKING PLAN
9	C	PASSIVE IRRIGATION PLAN

SERVICE OFFSETS AND LOCATION TABLE

ROAD NAME	ROAD RESERVE	SIDE	POTABLE WATER OFFSET	GAS SIDE	ELECTRICITY POLE OFFSET	ELECTRICITY U/G CABLE SIDE	TELECOMMUNICATIONS SIDE	BOK	
								OFFSET	SIDE
FAULKS STREET	16m	W	2.30	W	1.80	1.00*	E	2.40	E 1.80, W 4.20
ASHFORDBY STREET	19m	W	2.30	W	1.80	1.00*	E	3.30	E 5.70, W 5.70

1. TELSTRA AND ELECTRICITY CABLES ARE TO BE CONSTRUCTED IN A COMMON TRENCH IN ACCORDANCE WITH ELECTRICITY AUTHORITY STANDARD DRAWINGS.
2. GAS AND WATER MAINS ARE TO BE CONSTRUCTED IN A COMMON TRENCH.
3. * DENOTES OFFSET FROM BACK OF KERB.

ATTENTION TO CONTRACTOR

- IT IS THE CONTRACTORS RESPONSIBILITY TO ENSURE THAT THE DIGITAL PLAN, PROVIDED FOR SETOUT PURPOSES, MATCHES THE TBM COORDINATES SHOWN.
- Contractor to ensure that the site is pegged by a licenced surveyor and set out checked by a licenced surveyor prior to underground infrastructure being installed.
- Where concrete works abut a sewer access chamber surround or similar structure, an expansion joint of approved material shall be provided between the two faces.

SYMBOL LEGEND	
Drains	Prop Prev Stage
Sewer < 3000	Ex/Natural/FS Level
Sewer ≥ 3000	FS @ Building Line
Water (DW)	Top/Toe Batter Level
Water (NDW)	Top/Bottom RW Level
House Drain	100yr Flood Level
Property Inlet	Fill Proposed (<0.3m/±0.3m)
Street Sign	Cut Proposed
PSM	Asphalt Surface Prop
Rock Ret Wall	Concrete Surface Prop (Paths/Driveways/Slabs)
Sleeper Ret Wall	Tree To Be Removed
Conduits 50mm	Tree To Be Retained with Tree Protection Zone (TPZ)
Conduits 100mm	
Street Tree without/with Passive Irrigation (Refer Detail)	
Ex Drains	
Ex Water DWN/DW	
Ex Sewer/Gas	
Ex Elect/Comm	

AMENDMENTS	DATE	REMARKS	CHECKED	SCALE	DATUM	AHD	DATE	SHEET	OF	F
F	01-04-25	NOTE ADDED FOR LOT 416								
E	13-03-25	DRAWING INDEX AMENDED								
D	18-02-25	DRAWING INDEX AMENDED								
C	24-10-24	SERVICE OFFSET TABLE AMENDED								
B	11-10-24	HOUSE DRAIN OFFSET FOR LOT 419 AMENDED								
A	29-05-24	ISSUED FOR CONSTRUCTION								
VER	DATE	REMARKS	CHECKED	SCALE	DATUM	AHD	DATE	SHEET	OF	F

brees pitt dixon pty. ltd.
land surveyors civil engineers

1/19 cato street hawthorn east, 3123 telephone 8823 2300 fax no. 8823 2310

ELINYA ESTATE STAGE 4
LAYOUT PLAN & SERVICE OFFSETS TABLE

MELWAY REF. 355-D-4
SURVEY BPD
DESIGN M.A.
DRAWN M.A.

MUNICIPALITY MELTON
REFERENCE 9980 / 4
SHEET 1 OF 9

SCALE AS SHOWN
DATUM AHD
DATE FEB '23

Printed Apr 01 2025 - 03:59PM

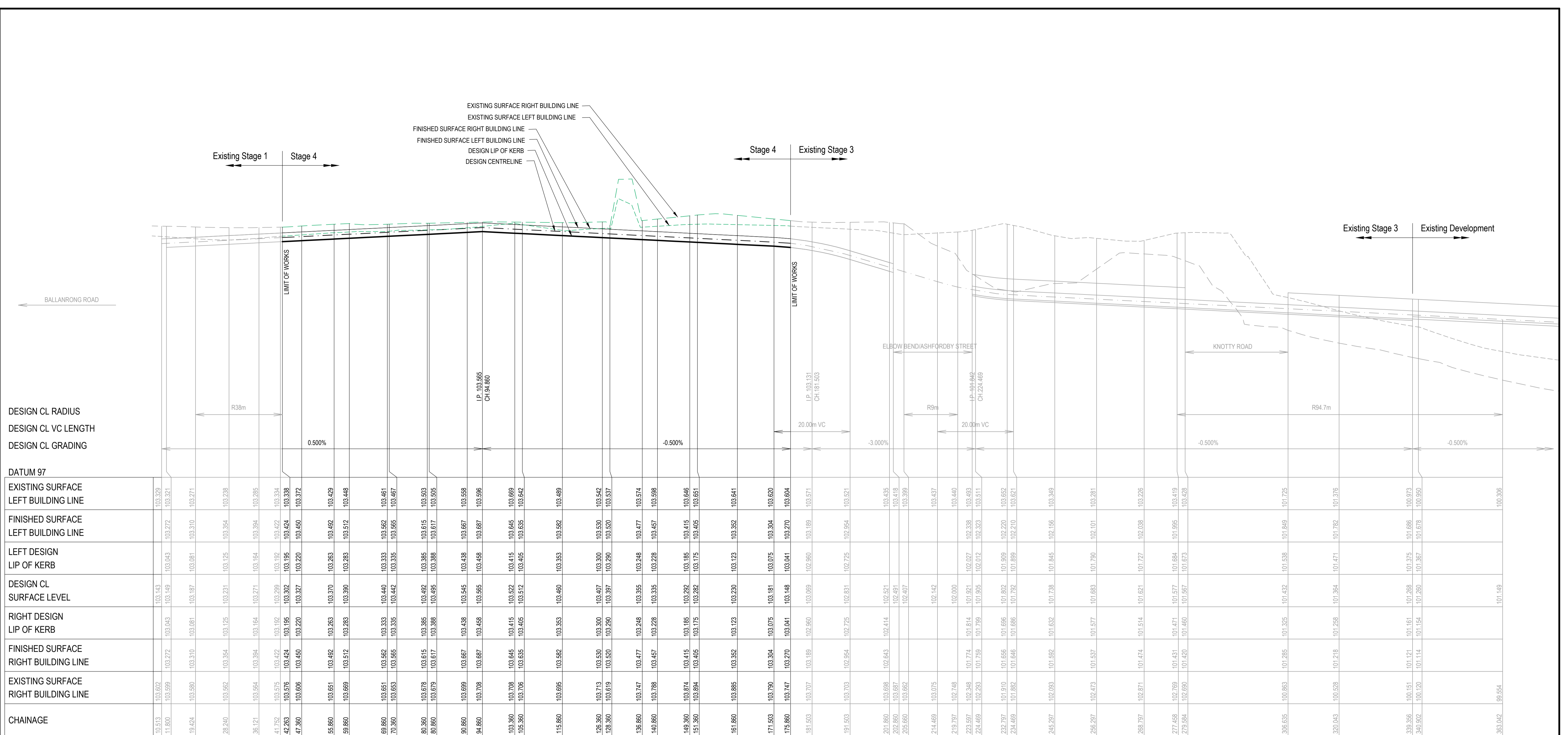

DESIGN CL RADIUS
DESIGN CL VC LENGTH
DESIGN CL GRADING

DATUM 97

EXISTING SURFACE LEFT BUILDING LINE	103.329	103.321	103.310	103.298	103.285	103.274	103.261	103.248	103.235	103.222	103.209	103.196	103.183	103.170	103.157	103.144	103.131	103.118	103.105	103.092	103.079	103.066	103.053	103.040	103.027	103.014	103.001	102.988	102.975	102.962	102.949	102.936	102.923	102.910	102.897	102.884	102.871	102.858	102.845	102.832	102.819	102.806	102.793	102.780	102.767	102.754	102.741	102.728	102.715	102.702	102.689	102.676	102.663	102.650	102.637	102.624	102.611	102.598	102.585	102.572	102.559	102.546	102.533	102.520	102.507	102.494	102.481	102.468	102.455	102.442	102.429	102.416	102.403	102.390	102.377	102.364	102.351	102.338	102.325	102.312	102.299	102.286	102.273	102.260	102.247	102.234	102.221	102.208	102.195	102.182	102.169	102.156	102.143	102.130	102.117	102.104	102.091	102.078	102.065	102.052	102.039	102.026	102.013	102.000	101.987	101.974	101.961	101.948	101.935	101.922	101.909	101.896	101.883	101.870	101.857	101.844	101.831	101.818	101.805	101.792	101.779	101.766	101.753	101.740	101.727	101.714	101.701	101.688	101.675	101.662	101.649	101.636	101.623	101.610	101.597	101.584	101.571	101.558	101.545	101.532	101.519	101.506	101.493	101.480	101.467	101.454	101.441	101.428	101.415	101.402	101.389	101.376	101.363	101.350	101.337	101.324	101.311	101.298	101.285	101.272	101.259	101.246	101.233	101.220	101.207	101.194	101.181	101.168	101.155	101.142	101.129	101.116	101.103	101.090	101.077	101.064	101.051	101.038	101.025	101.012	101.000	100.987	100.974	100.961	100.948	100.935	100.922	100.909	100.896	100.883	100.870	100.857	100.844	100.831	100.818	100.805	100.792	100.779	100.766	100.753	100.740	100.727	100.714	100.701	100.688	100.675	100.662	100.649	100.636	100.623	100.610	100.597	100.584	100.571	100.558	100.545	100.532	100.519	100.506	100.493	100.480	100.467	100.454	100.441	100.428	100.415	100.402	100.389	100.376	100.363	100.350	100.337	100.324	100.311	100.298	100.285	100.272	100.259	100.246	100.233	100.220	100.207	100.194	100.181	100.168	100.155	100.142	100.129	100.116	100.103	100.090	100.077	100.064	100.051	100.038	100.025	100.012	100.000	99.987	99.974	99.961	99.948	99.935	99.922	99.909	99.896	99.883	99.870	99.857	99.844	99.831	99.818	99.805	99.792	99.779	99.766	99.753	99.740	99.727	99.714	99.701	99.688	99.675	99.662	99.649	99.636	99.623	99.610	99.597	99.584	99.571	99.558	99.545	99.532	99.519	99.506	99.493	99.480	99.467	99.454	99.441	99.428	99.415	99.402	99.389	99.376	99.363	99.350	99.337	99.324	99.311	99.298	99.285	99.272	99.259	99.246	99.233	99.220	99.207	99.194	99.181	99.168	99.155	99.142	99.129	99.116	99.103	99.090	99.077	99.064	99.051	99.038	99.025	99.012	99.000	98.987	98.974	98.961	98.948	98.935	98.922	98.909	98.896	98.883	98.870	98.857	98.844	98.831	98.818	98.805	98.792	98.779	98.766	98.753	98.740	98.727	98.714	98.701	98.688	98.675	98.662	98.649	98.636	98.623	98.610	98.597	98.584	98.571	98.558	98.545	98.532	98.519	98.506	98.493	98.480	98.467	98.454	98.441	98.428	98.415	98.402	98.389	98.376	98.363	98.350	98.337	98.324	98.311	98.298	98.285	98.272	98.259	98.246	98.233	98.220	98.207	98.194	98.181	98.168	98.155	98.142	98.129	98.116	98.103	98.090	98.077	98.064	98.051	98.038	98.025	98.012	98.000	97.987	97.974	97.961	97.948	97.935	97.922	97.909	97.896	97.883	97.870	97.857	97.844	97.831	97.818	97.805	97.792	97.779	97.766	97.753	97.740	97.727	97.714	97.701	97.688	97.675	97.662	97.649	97.636	97.623	97.610	97.597	97.584	97.571	97.558	97.545	97.532	97.519	97.506	97.493	97.480	97.467	97.454	97.441	97.428	97.415	97.402	97.389	97.376	97.363	97.350	97.337	97.324	97.311	97.298	97.285	97.272	97.259	97.246	97.233	97.220	97.207	97.194	97.181	97.168	97.155	97.142	97.129	97.116	97.103	97.090	97.077	97.064	97.051	97.038	97.025	97.012	97.000	96.987	96.974	96.961	96.948	96.935	96.922	96.909	96.896	96.883	96.870	96.857	96.844	96.831	96.818	96.805	96.792	96.779	96.766	96.753	96.740	96.727	96.714	96.701	96.688	96.675	96.662	96.649	96.636	96.623	96.610	96.597	96.584	96.571	96.558	96.545	96.532	96.519	96.506	96.493	96.480	96.467	96.454	96.441	96.428	96.415	96.402	96.389	96.376	96.363	96.350	96.337	96.324	96.311	96.298	96.285	96.272	96.259	96.246	96.233	96.220	96.207	96.194	96.181	96.168	96.155	96.142	96.129	96.116	96.103	96.090	96.077	96.064	96.051	96.038	96.025	96.012	96.000	95.987	95.974	95.961	95.948	95.935	95.922	95.909	95.896	95.883	95.870	95.857	95.844	95.831	95.818	95.805	95.792	95.779	95.766	95.753	95.740	95.727	95.714	95.701	95.688	95.675	95.662	95.649	95.636	95.623	95.610	95.597	95.584	95.571	95.558	95.545	95.532	95.519	95.506	95.493	95.480	95.467	95.454	95.441	95.428	95.415	95.402	95.389	95.376	95.363	95.350	95.337	95.324	95.311	95.298	95.285	95.272	95.259	95.246	95.233	95.220	95.207	95.194	95.181	95.168	95.155	95.142	95.129	95.116	95.103	95.090	95.077	95.064	95.051	95.038	95.025	95.012	95.000	94.987	94.974	94.961	94.948	94.935	94.922	94.909	94.896	94.883	94.870	94.857	94.844	94.831	94.818	94.805	94.792	94.779	94.766	94.753	94.740	94.727	94.714	94.701	94.688	94.675	94.662	94.649	94.636	94.623	94.610	94.597	94.584	94.571	94.558	94.545	94.532	94.519	94.506	94.493	94.480	94.467	94.454	94.441	94.428	94.415	94.402	94.389	94.376	94.363	94.350	94.337	94.324	94.311	94.298	94.285	94.272	94.259	94.246	94.233	94.220	94.207	94.194	94.181	94.168	94.155	94.142	94.129	94.116	94.103	94.090	94.077	94.064	94.051	94.038	94.025	94.012	94.000	93.987	93.974	93.961	93.948	93.935	93.922	93.909	93.896	93.883	93.870	93.857	93.844	93.831	93.818	93.805	93.792	93.779	93.766	93.753	93.740	93.727	93.714	93.701	93.688	93.675	93.662	93.649	93.636	93.623	93.610	93.597	93.584	93.571	93.558	93.545	93.532	93.519	93.506	93.493	93.480	93.467	93.454	93.441	93.428	93.415	93.402	93.389	93.376	93.363	93.350	93.337	93.324	93.311	93.298	93.285	93.272	93.259	93.246	93.233	93.220	93.207	93.194	93.181	93.168	93.155	93.142	93.129	93.116	93.103	93.090	93.077	93.064	93.051	93.038	93.025	93.012	93.000	92.987	92.974	92.961	92.948	92.935	92.922	92.909	92.896	92.883	92.870	92.857	92.844	92.831	92.818	92.805	92.792	92.779	92.766	92.753	92.740	92.727	92.714	92.701	92.688	92.675	92.662	92.649	92.636	92.623	92.610	92.597	92.584	92.571	92.558	92.545	92.532	92.519	92.506	92.493	92.480	92.467	92.454	92.441	92.428	92.415	92.402	92.389	92.376	92.363	92.350	92.337	92.324	92.311	92.298	92.285	92.272	92.259	92.246	92.233	92.220	92.207	92.194	92.181	92.168	92.155	92.142	92.129	92.116	92.103	92.090	92.077	92.064	92.051	92.038	92.025	92.012	92.000	91.987	91.974	91.961	91.948	91.935	91.922	91.909	91.896	91.883	91.870	91.857	91.844	91.831	91.818	91.805	91.792	91.779	91.766	91.753	91.740	91.727	91.714	91.701	91.688	91.675	91.662	91.649	91.636	91.623	91.610	91.597	91.584	91.571	91.558	91.545	91.532	91.519	91.506	91.493	91.480	91.467	91.454	91.441	91.428	91.415	91.402	91.389	91.376	91.363	91.350	91.337	91.324	91.311	91.298	91.285	91.272	91.259	91.246	91.233	91.220	91.207	91.194	91.181	91.168	91.155	91.142	91.129	91.116	91.103	91.090	91.077	91.064	91.051	91.038	91.025	91.012	91.000	90.987	90.974	90.961	90.948	90.935	90.922	90.909	90.896	90.883	90.870	90.857	90.844	90.831	90.818	90.805	90.792	90.779	90.766	90.753	90.740	90.727	90.714	90.701	90.688	90.675	90.662	90.649	90.636	90.623	90.610	90.597	90.584	90.571	90.558	90.545	90.532	90.519	90.506	90.493	90.480	90.467	90.454	90.441	90.428	90.415	90.402	90.389	90.376	90.363	90.350	90.337	90.324	90.311	90.298	90.285	90.272	90.259	90.246	90.233	90.220	90.207	90.194	90.181	90.168	90.155	90.142	90.129	90.116	90.103	90.090	90.077	90.064	90.051	90.038	90.025	90.012	90.000	89.987	89.974	89.961	89.948	89.935	89.922	89.909	89.896	89.883	89.870	89.857	89.844	89.831	89.818	89.805	89.792	89.779	89.766	89.753	89.740	89.727	89.714	89.701	89.688	89.675	89.662	89.649	89.636	89.623	89.610	89.597	89.584	89.571	89.558	89.545	89.532	89.519	89.506	89.493	89.480	89.467	89.454	89.441	89.428	89.415	89.402	89.389	89.
-------------------------------------	---------	---------	---------	---------	---------	---------	---------	---------	---------	---------	---------	---------	---------	---------	---------	---------	---------	---------	---------	---------	---------	---------	---------	---------	---------	---------	---------	---------	---------	---------	---------	---------	---------	---------	---------	---------	---------	---------	---------	---------	---------	---------	---------	---------	---------	---------	---------	---------	---------	---------	---------	---------	---------	---------	---------	---------	---------	---------	---------	---------	---------	---------	---------	---------	---------	---------	---------	---------	---------	---------	---------	---------	---------	---------	---------	---------	---------	---------	---------	---------	---------	---------	---------	---------	---------	---------	---------	---------	---------	---------	---------	---------	---------	---------	---------	---------	---------	---------	---------	---------	---------	---------	---------	---------	---------	---------	---------	---------	---------	---------	---------	---------	---------	---------	---------	---------	---------	---------	---------	---------	---------	---------	---------	---------	---------	---------	---------	---------	---------	---------	---------	---------	---------	---------	---------	---------	---------	---------	---------	---------	---------	---------	---------	---------	---------	---------	---------	---------	---------	---------	---------	---------	---------	---------	---------	---------	---------	---------	---------	---------	---------	---------	---------	---------	---------	---------	---------	---------	---------	---------	---------	---------	---------	---------	---------	---------	---------	---------	---------	---------	---------	---------	---------	---------	---------	---------	---------	---------	---------	---------	---------	---------	---------	---------	---------	---------	---------	---------	---------	---------	---------	---------	---------	---------	---------	---------	---------	---------	---------	---------	---------	---------	---------	---------	---------	---------	---------	---------	---------	---------	---------	---------	---------	---------	---------	---------	---------	---------	---------	---------	---------	---------	---------	---------	---------	---------	---------	---------	---------	---------	---------	---------	---------	---------	---------	---------	---------	---------	---------	---------	---------	---------	---------	---------	---------	---------	---------	---------	--------	--------	--------	--------	--------	--------	--------	--------	--------	--------	--------	--------	--------	--------	--------	--------	--------	--------	--------	--------	--------	--------	--------	--------	--------	--------	--------	--------	--------	--------	--------	--------	--------	--------	--------	--------	--------	--------	--------	--------	--------	--------	--------	--------	--------	--------	--------	--------	--------	--------	--------	--------	--------	--------	--------	--------	--------	--------	--------	--------	--------	--------	--------	--------	--------	--------	--------	--------	--------	--------	--------	--------	--------	--------	--------	--------	--------	--------	--------	--------	--------	--------	--------	--------	--------	--------	--------	--------	--------	--------	--------	--------	--------	--------	--------	--------	--------	--------	--------	--------	--------	--------	--------	--------	--------	--------	--------	--------	--------	--------	--------	--------	--------	--------	--------	--------	--------	--------	--------	--------	--------	--------	--------	--------	--------	--------	--------	--------	--------	--------	--------	--------	--------	--------	--------	--------	--------	--------	--------	--------	--------	--------	--------	--------	--------	--------	--------	--------	--------	--------	--------	--------	--------	--------	--------	--------	--------	--------	--------	--------	--------	--------	--------	--------	--------	--------	--------	--------	--------	--------	--------	--------	--------	--------	--------	--------	--------	--------	--------	--------	--------	--------	--------	--------	--------	--------	--------	--------	--------	--------	--------	--------	--------	--------	--------	--------	--------	--------	--------	--------	--------	--------	--------	--------	--------	--------	--------	--------	--------	--------	--------	--------	--------	--------	--------	--------	--------	--------	--------	--------	--------	--------	--------	--------	--------	--------	--------	--------	--------	--------	--------	--------	--------	--------	--------	--------	--------	--------	--------	--------	--------	--------	--------	--------	--------	--------	--------	--------	--------	--------	--------	--------	--------	--------	--------	--------	--------	--------	--------	--------	--------	--------	--------	--------	--------	--------	--------	--------	--------	--------	--------	--------	--------	--------	--------	--------	--------	--------	--------	--------	--------	--------	--------	--------	--------	--------	--------	--------	--------	--------	--------	--------	--------	--------	--------	--------	--------	--------	--------	--------	--------	--------	--------	--------	--------	--------	--------	--------	--------	--------	--------	--------	--------	--------	--------	--------	--------	--------	--------	--------	--------	--------	--------	--------	--------	--------	--------	--------	--------	--------	--------	--------	--------	--------	--------	--------	--------	--------	--------	--------	--------	--------	--------	--------	--------	--------	--------	--------	--------	--------	--------	--------	--------	--------	--------	--------	--------	--------	--------	--------	--------	--------	--------	--------	--------	--------	--------	--------	--------	--------	--------	--------	--------	--------	--------	--------	--------	--------	--------	--------	--------	--------	--------	--------	--------	--------	--------	--------	--------	--------	--------	--------	--------	--------	--------	--------	--------	--------	--------	--------	--------	--------	--------	--------	--------	--------	--------	--------	--------	--------	--------	--------	--------	--------	--------	--------	--------	--------	--------	--------	--------	--------	--------	--------	--------	--------	--------	--------	--------	--------	--------	--------	--------	--------	--------	--------	--------	--------	--------	--------	--------	--------	--------	--------	--------	--------	--------	--------	--------	--------	--------	--------	--------	--------	--------	--------	--------	--------	--------	--------	--------	--------	--------	--------	--------	--------	--------	--------	--------	--------	--------	--------	--------	--------	--------	--------	--------	--------	--------	--------	--------	--------	--------	--------	--------	--------	--------	--------	--------	--------	--------	--------	--------	--------	--------	--------	--------	--------	--------	--------	--------	--------	--------	--------	--------	--------	--------	--------	--------	--------	--------	--------	--------	--------	--------	--------	--------	--------	--------	--------	--------	--------	--------	--------	--------	--------	--------	--------	--------	--------	--------	--------	--------	--------	--------	--------	--------	--------	--------	--------	--------	--------	--------	--------	--------	--------	--------	--------	--------	--------	--------	--------	--------	--------	--------	--------	--------	--------	--------	--------	--------	--------	--------	--------	--------	--------	--------	--------	--------	--------	--------	--------	--------	--------	--------	--------	--------	--------	--------	--------	--------	--------	--------	--------	--------	--------	--------	--------	--------	--------	--------	--------	--------	--------	--------	--------	--------	--------	--------	--------	--------	--------	--------	--------	--------	--------	--------	--------	--------	--------	--------	--------	--------	--------	--------	--------	--------	--------	--------	--------	--------	--------	--------	--------	--------	--------	--------	--------	--------	--------	--------	--------	--------	--------	--------	--------	--------	--------	--------	--------	--------	--------	--------	--------	--------	--------	--------	--------	--------	--------	--------	--------	--------	--------	--------	--------	--------	--------	--------	--------	--------	--------	--------	--------	--------	--------	--------	--------	--------	--------	--------	--------	--------	--------	--------	--------	--------	--------	--------	--------	--------	--------	--------	--------	--------	--------	--------	--------	--------	--------	--------	--------	--------	--------	--------	--------	--------	--------	--------	--------	--------	--------	--------	--------	--------	--------	--------	--------	--------	--------	--------	--------	--------	--------	--------	--------	--------	--------	--------	--------	--------	--------	--------	--------	--------	--------	--------	--------	--------	--------	--------	--------	--------	--------	--------	--------	--------	--------	--------	--------	--------	--------	--------	--------	--------	--------	--------	--------	--------	--------	--------	--------	--------	--------	--------	--------	--------	--------	--------	--------	--------	--------	--------	--------	--------	--------	--------	--------	--------	--------	--------	--------	--------	--------	--------	--------	--------	--------	--------	--------	--------	--------	--------	--------	--------	--------	--------	--------	--------	--------	--------	--------	--------	--------	--------	--------	--------	--------	--------	--------	--------	--------	--------	--------	--------	--------	--------	--------	--------	--------	--------	--------	--------	--------	--------	--------	--------	-----

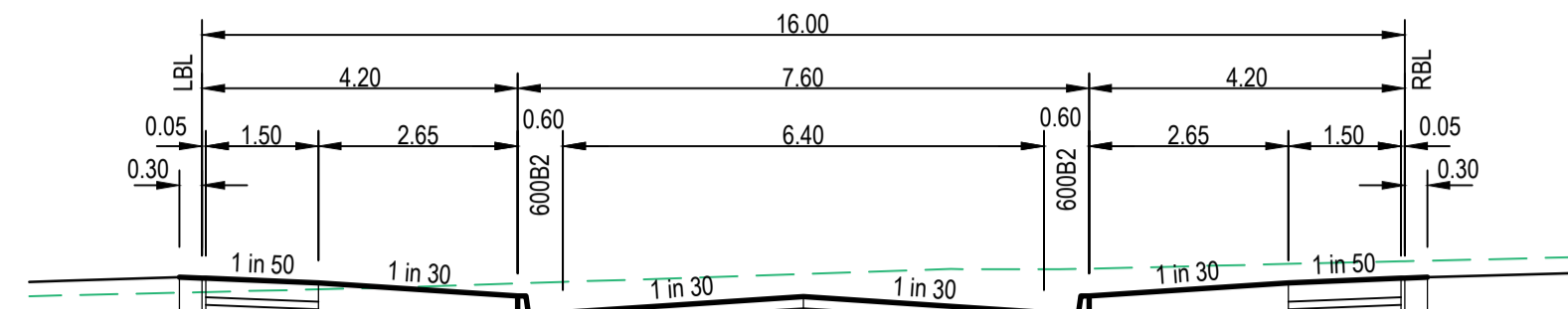

DATUM 102.5	
DESIGN SURFACE LEVEL	103.588, 103.582, 103.581, 103.551, 103.463, 103.313, 103.353, 103.460, 103.313, 103.353, 103.463, 103.551, 103.581, 103.582, 103.588
EXISTING SURFACE LEVEL	103.486, 103.489, 103.490, 103.508, 103.547, 103.549, 103.557, 103.610, 103.641, 103.643, 103.645, 103.676, 103.694, 103.694, 103.698
OFFSET	-8.300, -8.000, -7.950, -6.450, -3.800, -3.650, -3.200, 0.000, 3.200, 3.650, 3.800, 6.450, 7.950, 8.000, 8.300

FAULKES STREET CH 115.860

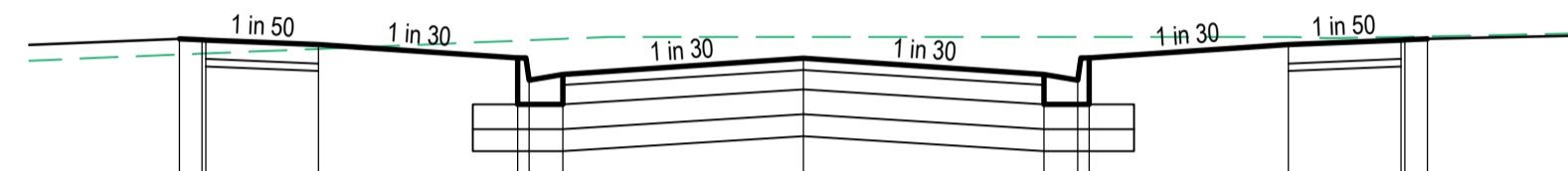

DATUM 102.5	
DESIGN SURFACE LEVEL	103.693, 103.687, 103.686, 103.656, 103.568, 103.418, 103.458, 103.565, 103.418, 103.458, 103.565, 103.656, 103.686, 103.687, 103.693
EXISTING SURFACE LEVEL	103.590, 103.596, 103.596, 103.627, 103.682, 103.685, 103.694, 103.706, 103.706, 103.706, 103.706, 103.706, 103.706, 103.708, 103.687, 103.693
OFFSET	-8.300, -8.000, -7.950, -6.450, -3.800, -3.650, -3.200, 0.000, 3.200, 3.650, 3.800, 6.450, 7.950, 8.000, 8.300

FAULKES STREET CH 94.860

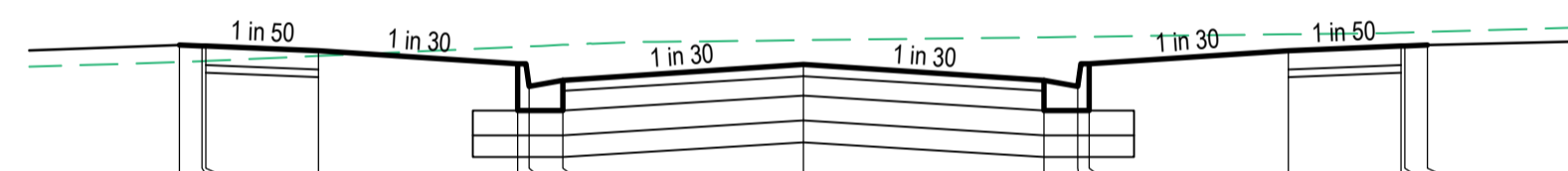

DATUM 102.5	
DESIGN SURFACE LEVEL	103.568, 103.562, 103.561, 103.531, 103.443, 103.293, 103.333, 103.440, 103.293, 103.333, 103.443, 103.531, 103.561, 103.562, 103.568
EXISTING SURFACE LEVEL	103.455, 103.461, 103.462, 103.496, 103.556, 103.559, 103.569, 103.601, 103.620, 103.623, 103.624, 103.640, 103.651, 103.662, 103.668
OFFSET	-8.300, -8.000, -7.950, -6.450, -3.800, -3.650, -3.200, 0.000, 3.200, 3.650, 3.800, 6.450, 7.950, 8.000, 8.300

FAULKES STREET CH 69.860

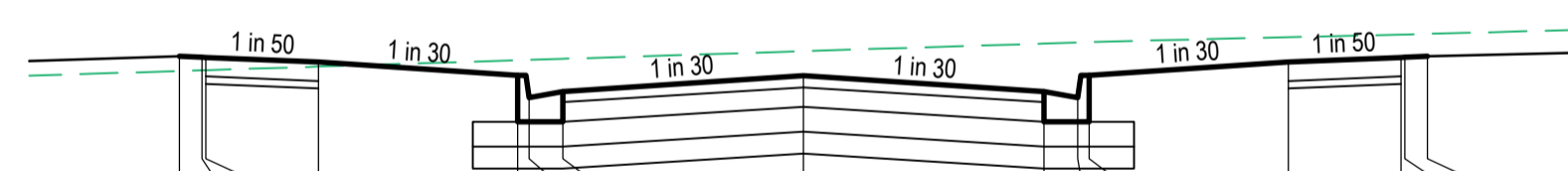

DATUM 102.5	
DESIGN SURFACE LEVEL	103.430, 103.424, 103.423, 103.393, 103.305, 103.155, 103.195, 103.302, 103.155, 103.195, 103.305, 103.393, 103.423, 103.424, 103.430
EXISTING SURFACE LEVEL	103.333, 103.338, 103.338, 103.362, 103.404, 103.407, 103.414, 103.465, 103.516, 103.523, 103.525, 103.558, 103.575, 103.576, 103.580
OFFSET	-8.300, -8.000, -7.950, -6.450, -3.800, -3.650, -3.200, 0.000, 3.200, 3.650, 3.800, 6.450, 7.950, 8.000, 8.300

FAULKES STREET CH 42.263 (LIMIT OF WORKS)

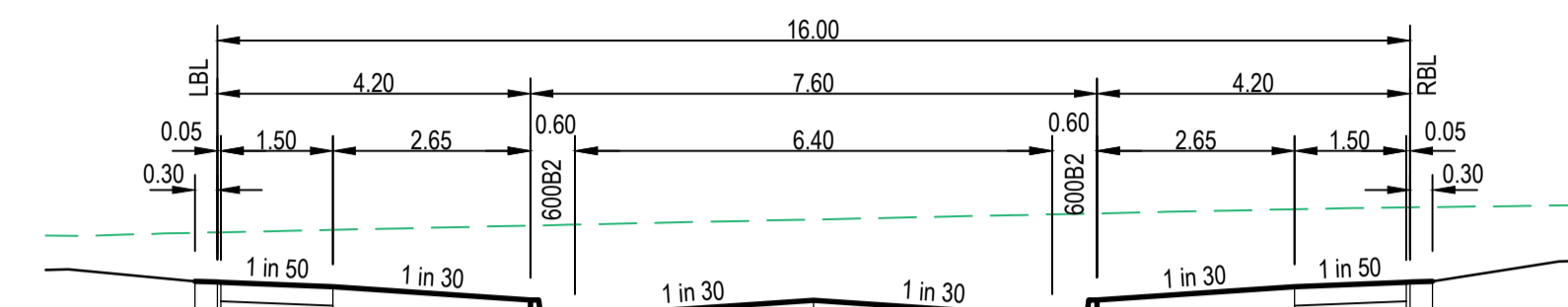

DATUM 102	
DESIGN SURFACE LEVEL	103.276, 103.270, 103.269, 103.239, 103.151, 103.001, 103.041, 103.148, 103.001, 103.041, 103.151, 103.239, 103.269, 103.270, 103.276
EXISTING SURFACE LEVEL	103.601, 103.604, 103.605, 103.621, 103.649, 103.651, 103.651, 103.690, 103.690, 103.690, 103.690, 103.690, 103.690, 103.690, 103.690
OFFSET	-8.300, -8.000, -7.950, -6.450, -3.800, -3.650, -3.200, 0.000, 3.200, 3.650, 3.800, 6.450, 7.950, 8.000, 8.300

FAULKES STREET CH 175.860 (LIMIT OF WORKS)

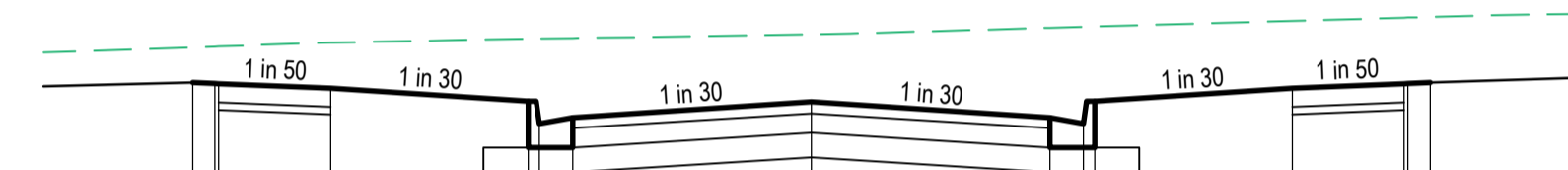

DATUM 102	
DESIGN SURFACE LEVEL	103.411, 103.405, 103.404, 103.374, 103.286, 103.135, 103.175, 103.282, 103.135, 103.175, 103.286, 103.374, 103.404, 103.405, 103.411
EXISTING SURFACE LEVEL	103.646, 103.651, 103.652, 103.678, 103.703, 103.704, 103.708, 103.735, 103.735, 103.735, 103.735, 103.735, 103.735, 103.735, 103.735
OFFSET	-8.300, -8.000, -7.950, -6.450, -3.800, -3.650, -3.200, 0.000, 3.200, 3.650, 3.800, 6.450, 7.950, 8.000, 8.300

FAULKES STREET CH 151.360

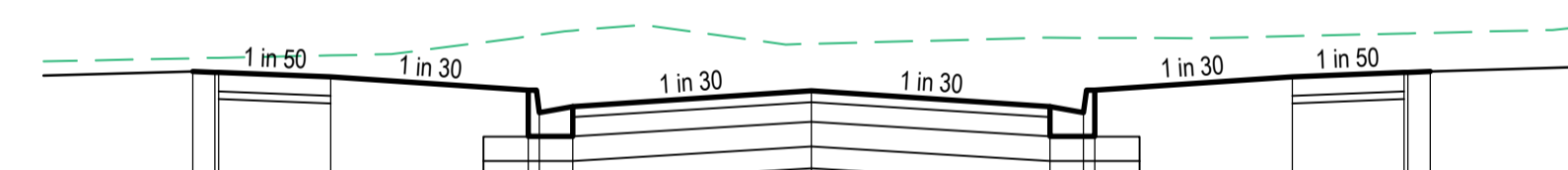

DATUM 102.5	
DESIGN SURFACE LEVEL	103.483, 103.477, 103.476, 103.446, 103.358, 103.208, 103.248, 103.355, 103.208, 103.248, 103.358, 103.446, 103.476, 103.477, 103.483
EXISTING SURFACE LEVEL	103.571, 103.574, 103.575, 103.575, 103.575, 103.575, 103.575, 103.668, 103.668, 103.668, 103.668, 103.668, 103.668, 103.668, 103.668
OFFSET	-8.300, -8.000, -7.950, -6.450, -3.800, -3.650, -3.200, 0.000, 3.200, 3.650, 3.800, 6.450, 7.950, 8.000, 8.300

FAULKES STREET CH 136.860

FAULKES STREET CROSS SECTIONS

SCALE: H 1:100, V 1:50

CRUSHED ROCK BACKFILL

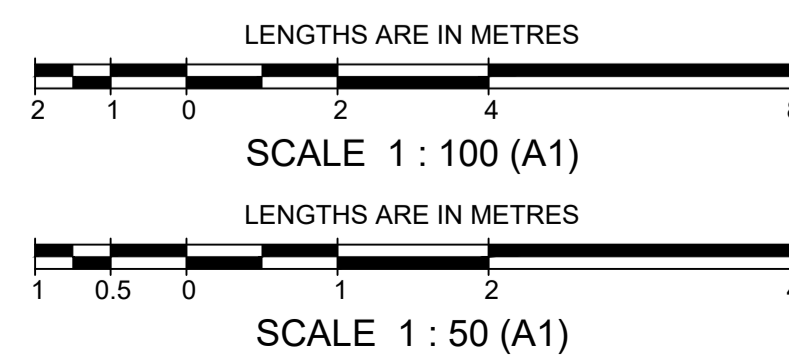

WARNING
BEWARE OF UNDERGROUND SERVICES
THE LOCATIONS OF UNDERGROUND SERVICES ARE APPROXIMATE ONLY AND THEIR EXACT POSITION SHOULD BE PROVEN ON SITE. NO GUARANTEE IS GIVEN THAT ALL EXISTING SERVICES ARE SHOWN.

		breese pitt dixon pty. ltd. land surveyors civil engineers		1/19 cato street hawthorn east, 3123 telephone 8823 2300 fax no. 8823 2310				
MELWAY REF. 355 D-4 SURVEY BPD DESIGN M.A. DRAWN M.A.		ELINYA ESTATE STAGE 4 ROAD CROSS SECTIONS FAULKES STREET		MUNICIPALITY MELTON				
AMENDMENTS A 29-05-24 ISSUED FOR CONSTRUCTION				REFERENCE 9980 E/4				
VER	DATE	REMARKS	CHECKED	SCALE AS SHOWN	DATUM AHD	DATE FEB '23	SHEET 4 OF 9	A

WARNING
 BEWARE OF UNDERGROUND SERVICES
 THE LOCATIONS OF UNDERGROUND SERVICES ARE APPROXIMATE ONLY AND THEIR EXACT POSITION SHOULD BE PROVEN ON SITE. NO GUARANTEE IS GIVEN THAT ALL EXISTING SERVICES ARE SHOWN.

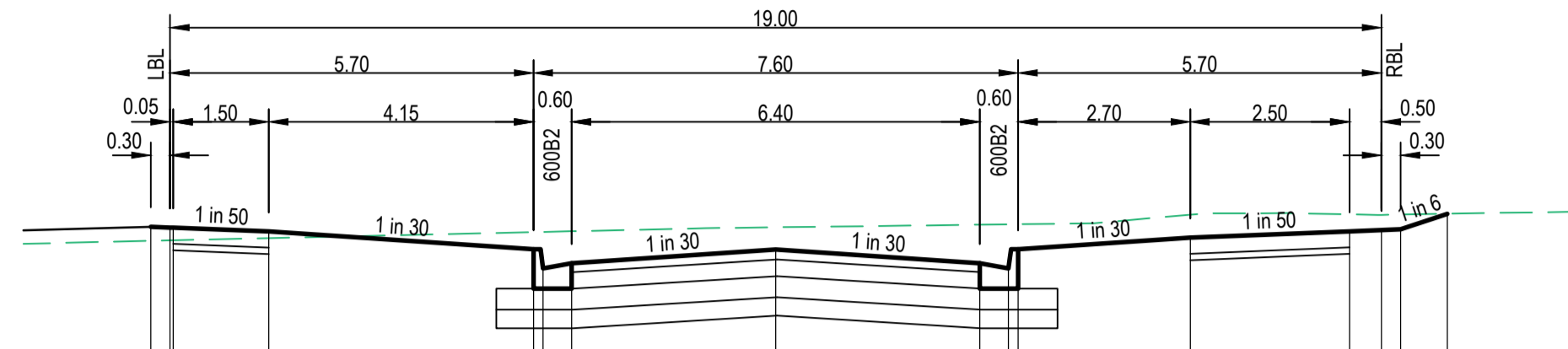

DATUM 103	
DESIGN SURFACE LEVEL	104.354, 104.348, 104.347, 104.317, 104.179, 104.029, 104.069, 104.176, 104.069, 104.319, 104.329, 104.335, 104.457, 104.457
EXISTING SURFACE LEVEL	104.244, 104.248, 104.248, 104.265, 104.313, 104.314, 104.320, 104.351, 104.371, 104.374, 104.375, 104.450, 104.452, 104.448, 104.451, 104.457
OFFSET	-9.800, -9.500, -9.450, -7.950, -3.800, -3.650, -3.200, 0.000, 3.200, 3.650, 3.800, 6.500, 9.000, 9.500, 9.800, 10.530

ASHFORDBY STREET

CH 361.196

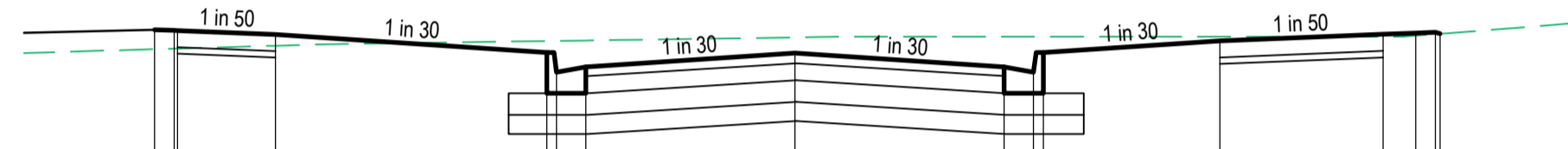

DATUM 103	
DESIGN SURFACE LEVEL	104.306, 104.300, 104.299, 104.269, 104.131, 103.981, 104.021, 104.127, 104.021, 104.271, 104.281, 104.287, 104.275, 104.275
EXISTING SURFACE LEVEL	104.157, 104.161, 104.162, 104.184, 104.219, 104.221, 104.224, 104.247, 104.253, 104.261, 104.272, 104.275, 104.275
OFFSET	-9.800, -9.500, -9.450, -7.950, -3.800, -3.650, -3.200, 0.000, 3.200, 3.650, 3.800, 6.500, 9.000, 9.500, 9.800, 9.871

ASHFORDBY STREET

CH 340.173

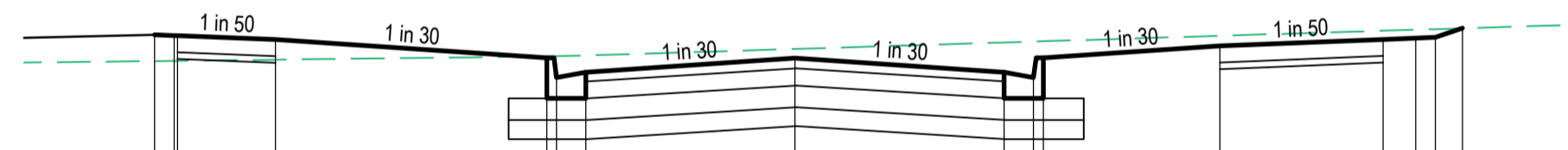

DATUM 103	
DESIGN SURFACE LEVEL	104.181, 104.175, 104.174, 104.144, 104.006, 103.856, 104.006, 104.002, 103.896, 104.146, 104.156, 104.162, 104.231, 104.231
EXISTING SURFACE LEVEL	103.990, 103.992, 103.992, 104.174, 104.017, 104.018, 104.023, 104.073, 104.122, 104.212, 104.220, 104.224, 104.231, 104.231
OFFSET	-9.800, -9.500, -9.450, -7.950, -3.800, -3.650, -3.200, 0.000, 3.200, 3.650, 3.800, 6.500, 9.000, 9.500, 9.800, 10.214

ASHFORDBY STREET

CH 315.146

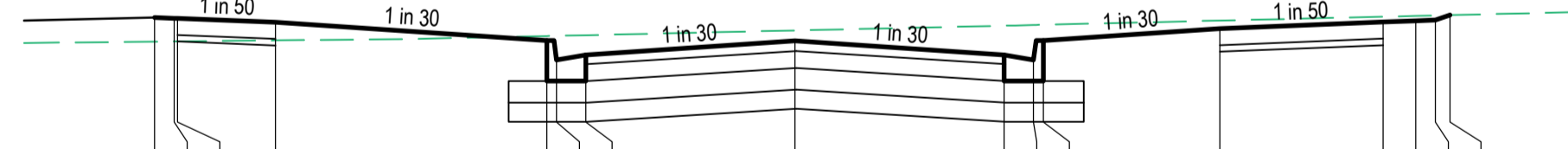

DATUM 103	
DESIGN SURFACE LEVEL	104.048, 104.042, 104.041, 104.011, 103.873, 103.723, 103.763, 103.870, 103.763, 104.013, 104.023, 104.029, 104.066, 104.066
EXISTING SURFACE LEVEL	103.864, 103.866, 103.866, 104.041, 103.907, 103.906, 103.913, 103.949, 103.991, 104.054, 104.060, 104.064, 104.066, 104.066
OFFSET	-9.800, -9.500, -9.450, -7.950, -3.800, -3.650, -3.200, 0.000, 3.200, 3.650, 3.800, 6.500, 9.000, 9.500, 9.800, 10.023

ASHFORDBY STREET

CH 288.617 (LIMIT OF WORKS)

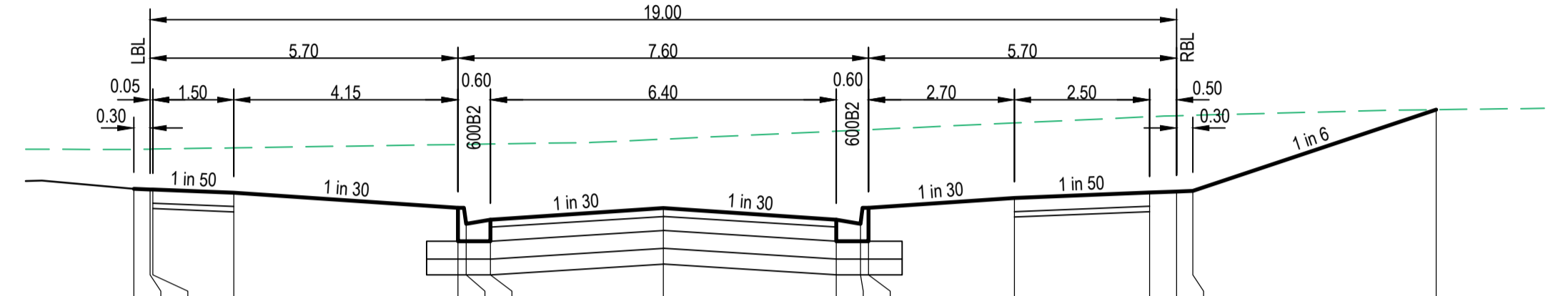

DATUM 103	
DESIGN SURFACE LEVEL	104.046, 104.040, 104.039, 104.009, 103.871, 103.721, 103.761, 103.868, 103.761, 104.011, 104.021, 104.027, 104.778, 104.778
EXISTING SURFACE LEVEL	104.411, 104.413, 104.413, 104.425, 104.456, 104.457, 104.460, 104.505, 104.579, 104.579, 104.579, 104.713, 104.778
OFFSET	-9.800, -9.500, -9.450, -7.950, -3.800, -3.650, -3.200, 0.000, 3.200, 3.650, 3.800, 6.500, 9.000, 9.500, 9.800, 14.307

ASHFORDBY STREET

CH 422.762 (LIMIT OF WORKS)

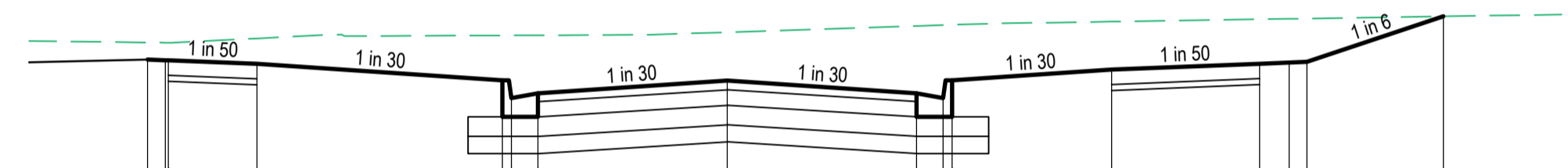

DATUM 103	
DESIGN SURFACE LEVEL	104.169, 104.163, 104.162, 104.132, 103.994, 103.844, 103.884, 103.990, 103.884, 104.134, 104.144, 104.150, 104.534, 104.534
EXISTING SURFACE LEVEL	104.314, 104.312, 104.311, 104.347, 104.373, 104.373, 104.374, 104.400, 104.453, 104.510, 104.514, 104.516, 104.534, 104.534
OFFSET	-9.800, -9.500, -9.450, -7.950, -3.800, -3.650, -3.200, 0.000, 3.200, 3.650, 3.800, 6.500, 9.000, 9.500, 9.800, 12.108

ASHFORDBY STREET

CH 398.236

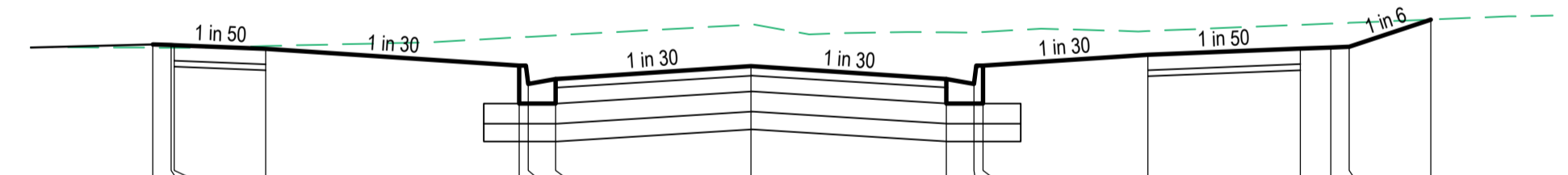

DATUM 103	
DESIGN SURFACE LEVEL	104.264, 104.278, 104.277, 104.247, 104.109, 103.959, 103.999, 104.106, 103.999, 104.249, 104.249, 104.263, 104.488, 104.488
EXISTING SURFACE LEVEL	104.257, 104.256, 104.256, 104.270, 104.342, 104.346, 104.358, 104.446, 104.383, 104.444, 104.444, 104.460, 104.488, 104.488
OFFSET	-9.800, -9.500, -9.450, -7.950, -3.800, -3.650, -3.200, 0.000, 3.200, 3.650, 3.800, 6.500, 9.000, 9.500, 9.800, 11.136

ASHFORDBY STREET

CH 375.211

ASHFORDBY STREET CROSS SECTIONS

SCALE: H 1:100, V 1:50

CRUSHED ROCK BACKFILL

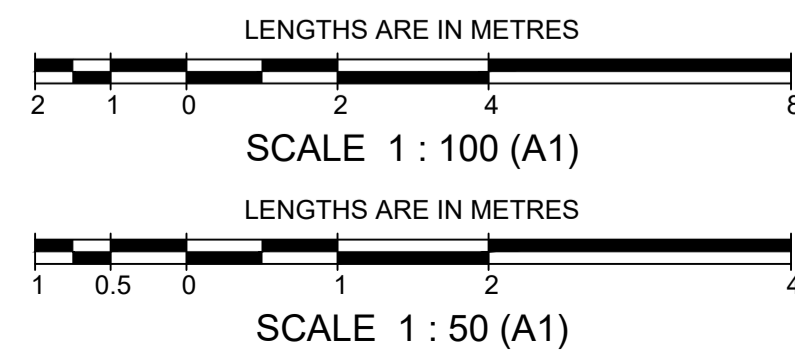

		breese pitt dixon pty. ltd. land surveyors civil engineers		1/19 cato street hawthorn east, 3123 telephone 8823 2300 fax no. 8823 2310	
MELWAY REF. 355 D-4		ELINYA ESTATE STAGE 4 ROAD CROSS SECTIONS ASHFORDBY STREET		MUNICIPALITY MELTON	
SURVEY BPD		DESIGN M.A.		REFERENCE 9980 E/4	
DRAWN M.A.		CHECKED		SCALE AS SHOWN DATUM AHD DATE FEB '23 SHEET 6 OF 9	
AMENDMENTS	VER DATE	ISSUED FOR CONSTRUCTION	REMARKS	CHECKED	DATE

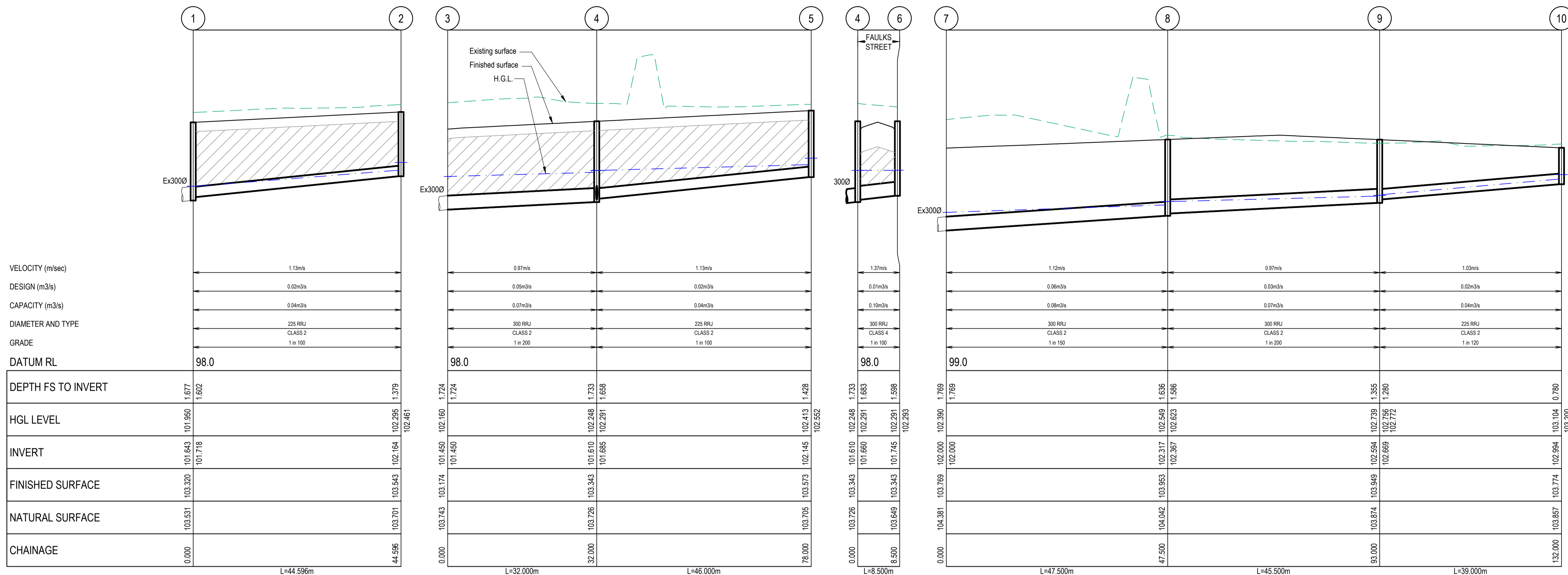

DRAINAGE LONGITUDINAL SECTIONS

SCALE: H 1:500, V 1:50

CRUSHED ROCK BACKFILL

DRAINAGE PIT SCHEDULE

PIT No	PIT TYPE	INTERNAL		INLET		OUTLET		FINISHED COVER RL	DEPTH	REMARKS
		WD	LEN	DIA	INV LEV	DIA	INV LEV			
1	Junction Pit	600	900	225	101.718	Ex300	101.643	103.320	1.677	EDCM 605, Construct pit over existing End Pipe
2	Junction Pit	600	900			225	102.164	103.543	1.379	EDCM 605
3	Existing End Pipe			300	101.450	Ex300	101.450	103.174	1.724	Connect to existing End Pipe
4	Grated Side Entry Pit	600	900	225	101.685	300	101.610	103.343	1.733	EDCM 601 (B2 Kerb)
				300	101.660					
5	Junction Pit	600	900			225	102.145	103.573	1.428	EDCM 605
6	Grated Side Entry Pit	600	900			300	101.745	103.343	1.598	EDCM 601 (B2 Kerb)
7	Existing End Pipe			300	102.000	Ex300	102.000	103.769	1.769	Connect to existing End Pipe
8	Junction Pit	600	900	300	102.367	300	102.317	103.953	1.636	EDCM 605
9	Junction Pit	600	900	225	102.669	300	102.594	103.949	1.355	EDCM 605
10	Junction Pit	600	900	225	102.994	225	102.994	103.774	0.780	EDCM 605
11	Existing Junction Pit	600	900	Ex300	102.142	Ex300	102.092	103.891	1.799	EDCM 601 (B2 Kerb), convert to Grated Side Entry Pit
12	Existing Junction Pit	600	900			Ex300	102.227	103.891	1.664	EDCM 601 (B2 Kerb), convert to Grated Side Entry Pit

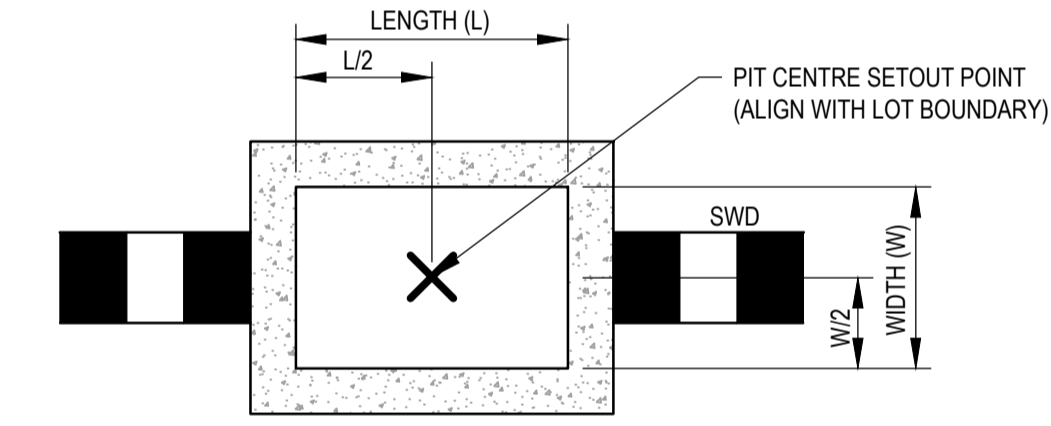

TYPICAL DRAINAGE PIT SETOUT POINT IN EASEMENT

NOT TO SCALE

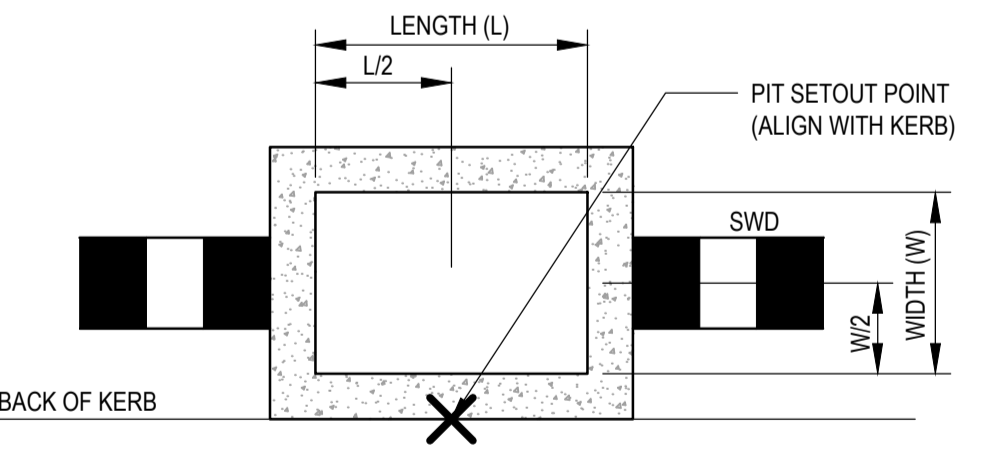

TYPICAL DRAINAGE PIT SETOUT POINT IN ROAD RESERVE

NOT TO SCALE

WARNING
BEWARE OF UNDERGROUND SERVICES
THE LOCATIONS OF UNDERGROUND SERVICES ARE APPROXIMATE ONLY AND THEIR EXACT POSITION SHOULD BE PROVEN ON SITE. NO GUARANTEE IS GIVEN THAT ALL EXISTING SERVICES ARE SHOWN.

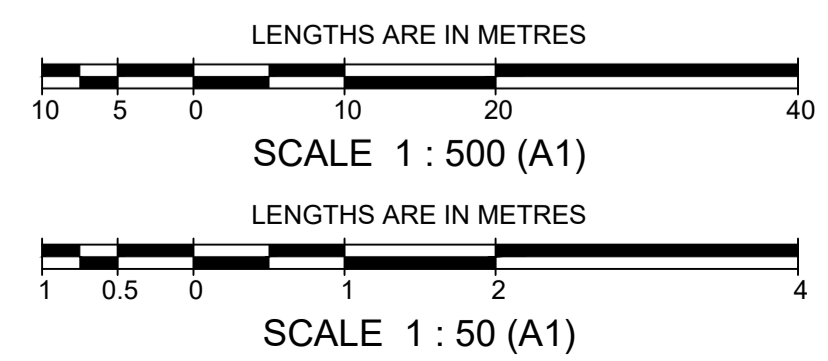

		breese pitt dixon pty. ltd. land surveyors civil engineers		1/19 cato street hawthorn east, 3123 telephone 8823 2300 fax no. 8823 2310	
MELWAY REF. 355 D-4 SURVEY BPD DESIGN M.A. DRAWN M.A.		ELINYA ESTATE STAGE 4 DRAINAGE LONGITUDINAL SECTIONS & PIT SCHEDULE		MUNICIPALITY MELTON REFERENCE 9980 E/4	
AMENDMENTS A 29-05-24 ISSUED FOR CONSTRUCTION	CHECKED	SCALE AS SHOWN	DATUM AHD	DATE FEB '23	SHEET 7 OF 9



LEGEND

- SPEED HUMP SIGN (BLACK & YELLOW)
- ADVISORY SPEED SIGN (BLACK & YELLOW)
- TGSi KERB RAMP
- TGSi DIRECTIONAL
- 1-WAY RRPM
- 2-WAY RRPM

WARNING
BEWARE OF UNDERGROUND SERVICES
THE LOCATIONS OF UNDERGROUND SERVICES ARE APPROXIMATE ONLY AND THEIR EXACT POSITION SHOULD BE PROVEN ON SITE. NO GUARANTEE IS GIVEN THAT ALL EXISTING SERVICES ARE SHOWN.

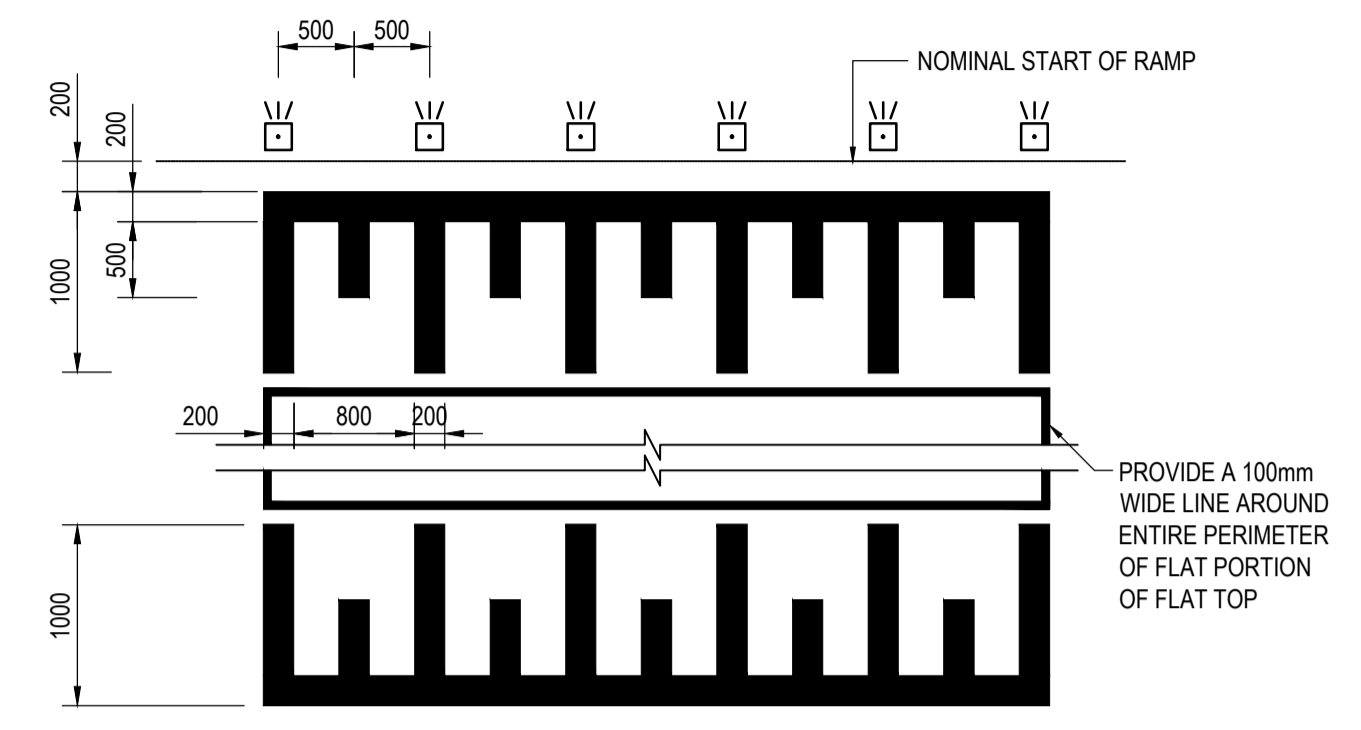

LINE MARKING FOR RAISED PAVEMENTS
NOT TO SCALE

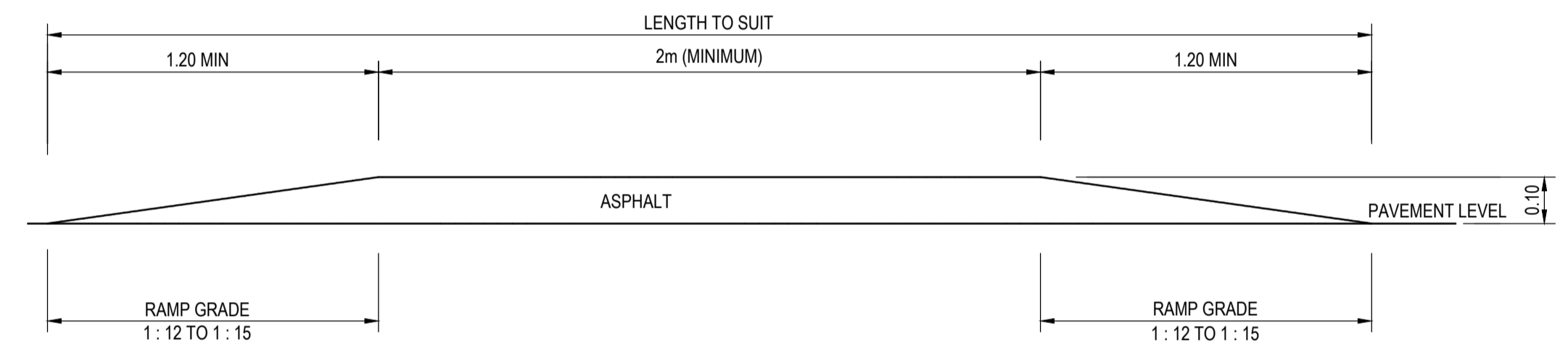
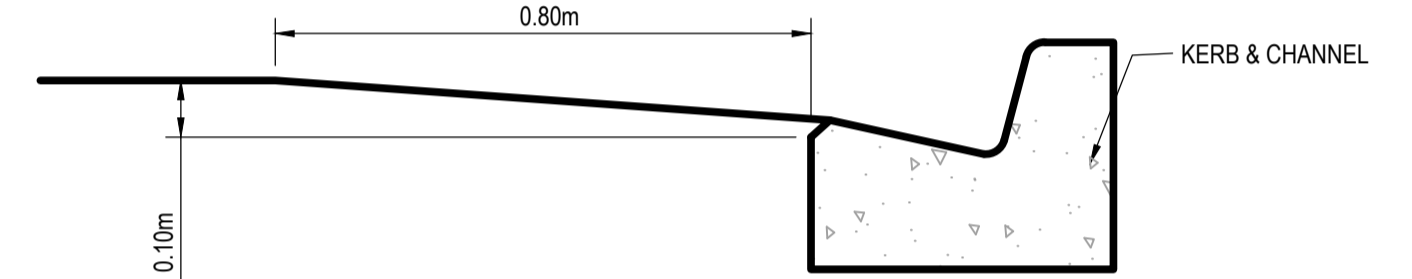

SETOUT DETAIL FOR RAISED PAVEMENT
NOT TO SCALE

NOTE: ASPHALT TO BE COMPACTED IN LAYERS NOT MORE THAN 50mm.

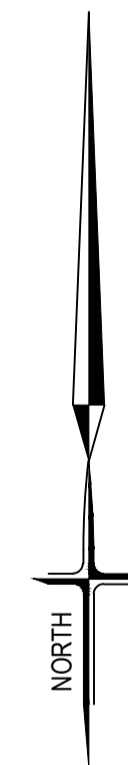

SIGNAGE & LINEMARKING PLAN

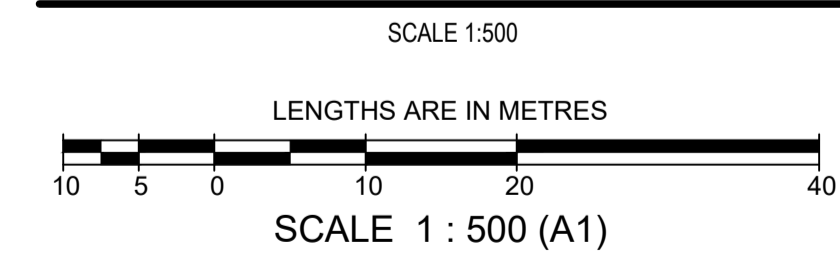

SYMBOL LEGEND

<ul style="list-style-type: none"> Drains Sewer < 3000 Sewer ≥ 3000 Water (DW) Water (NDW) House Drain Property Inlet Street Sign PSM Rock Ret Wall Sleeper Ret Wall Conduits 50mm Conduits 100mm Street Tree without/with Passive Irrigation (Refer Detail) Ex Drains Ex Water DW/NDW Ex Sewer/Gas Ex Elect/Comm 	<ul style="list-style-type: none"> Prop Prev Stage S W H PSM Rock Ret Wall Sleeper Ret Wall GW W100 Street Tree without/with Passive Irrigation (Refer Detail) Ex W Ex S Ex E Ex T 	<ul style="list-style-type: none"> Ex/Natural/FS Level FS @ Building Line Top/Toe Batter Level Top/Bottom RW Level 100yr Flood Level Fill Proposed (<0.3m/≥0.3m) Cut Proposed Asphalt Surface Prop Concrete Surface Prop (Paths/Driveways/Slabs) Tree To Be Removed Tree To Be Retained with Tree Protection Zone (TPZ) 	<ul style="list-style-type: none"> +28.57 +NS28.57 +FS28.57 +BL28.57 +TOP28.57 +TOE28.57 +TW28.57 +BW27.57 +FL28.57
--	---	---	--

		breese pitt dixon pty. ltd. land surveyors civil engineers		1/19 cato street hawthorn east, 3123 telephone 8823 2300 fax no. 8823 2310	
MELWAY REF. 355 D-4		ELINYA ESTATE STAGE 4		MUNICIPALITY MELTON	
SURVEY BPD		DESIGN M.A.		REFERENCE 9980 / 4	
DRAWN M.A.		SIGNAGE & LINEMARKING PLAN		DATE FEB '23	
VER A	DATE 29-05-24	ISSUED FOR CONSTRUCTION	CHECKED	SCALE AS SHOWN	DATUM AHD
SHEET 8 OF 9		A			

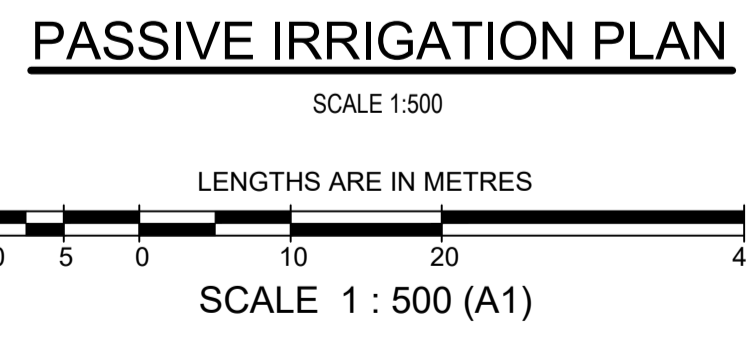
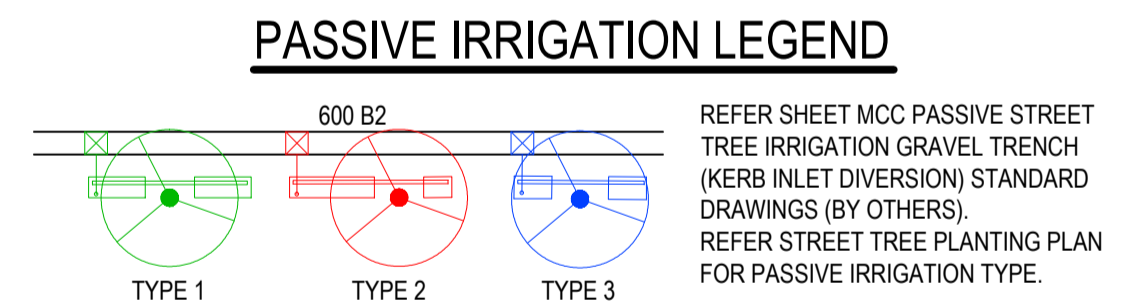
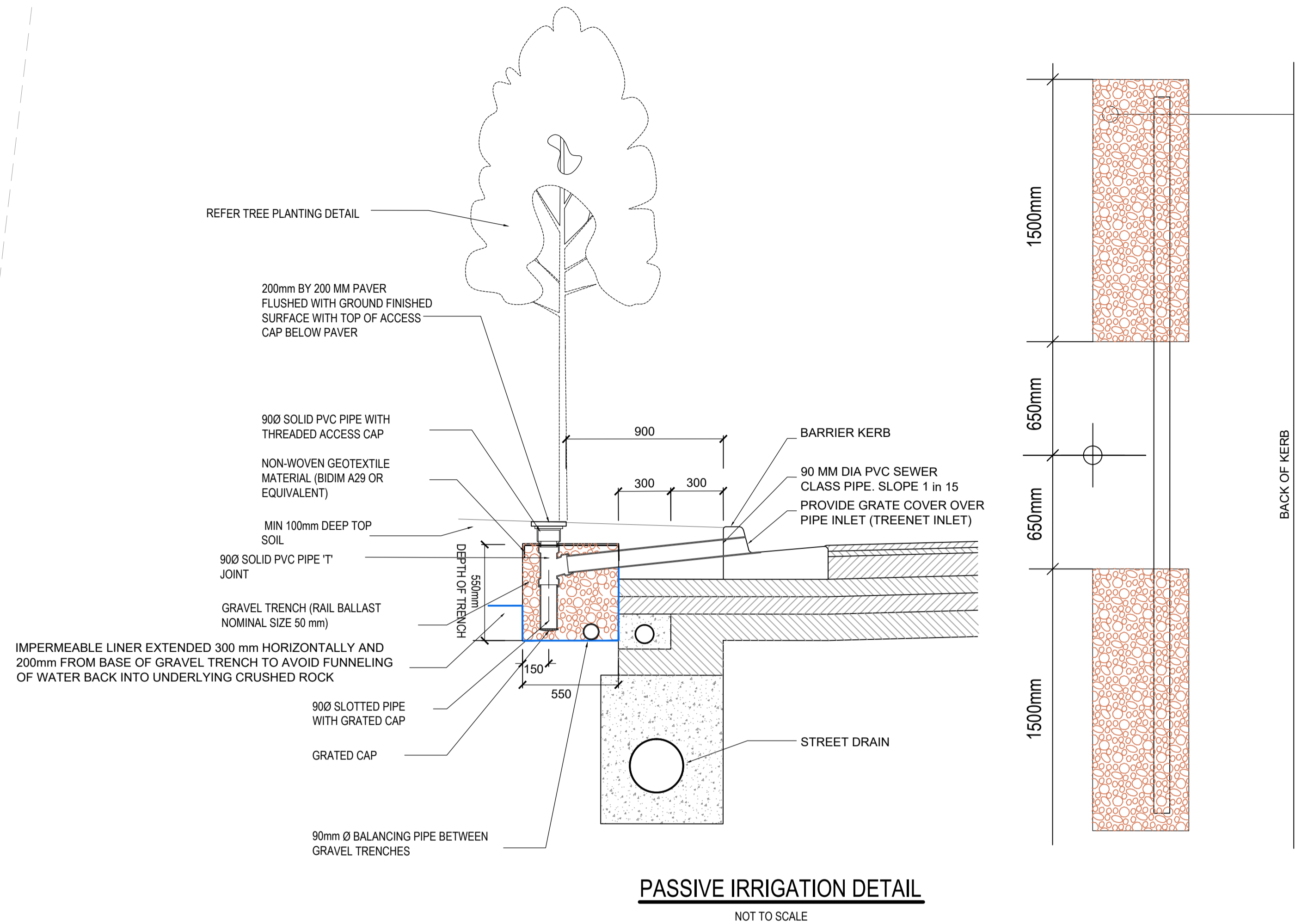
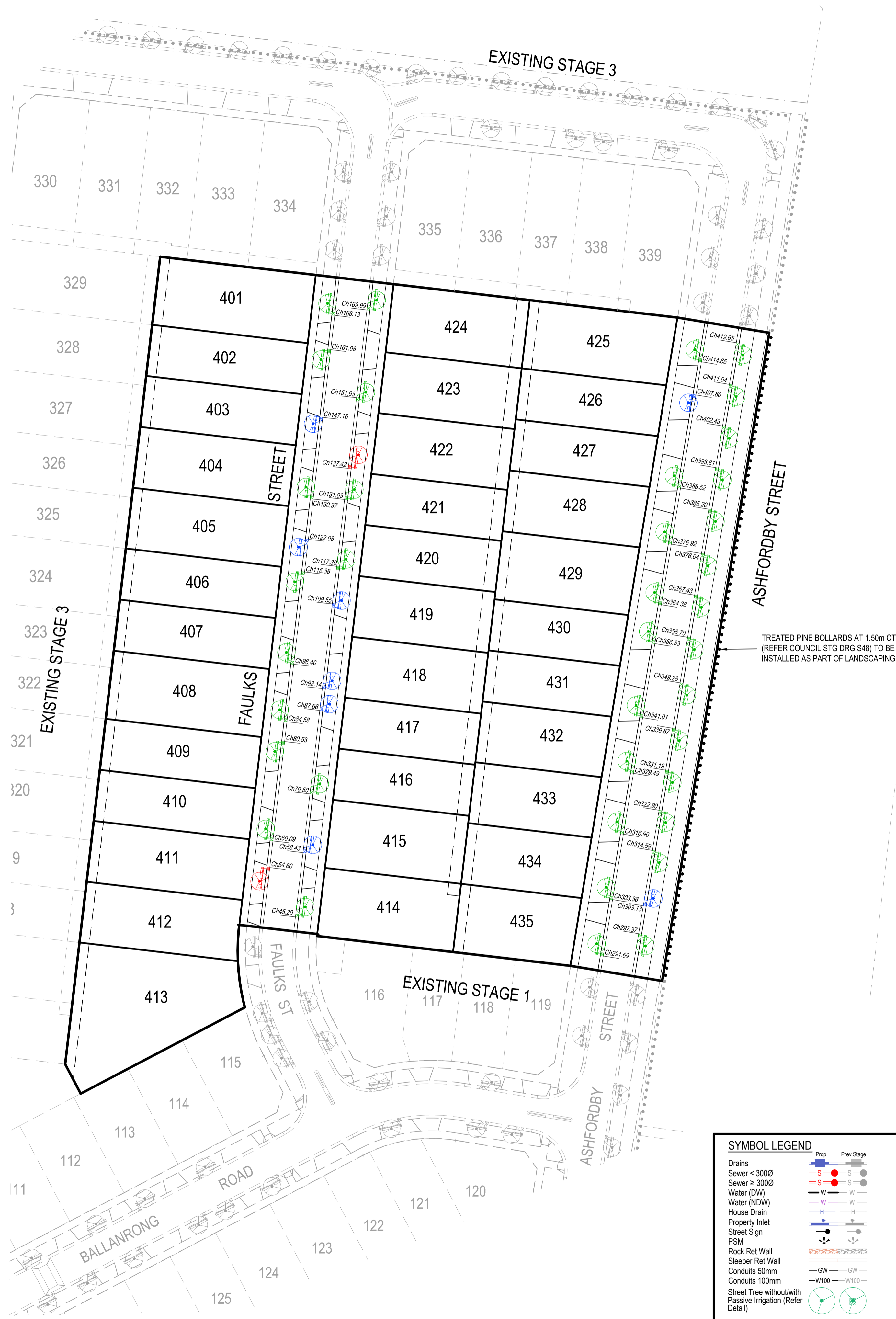

WARNING
BEWARE OF UNDERGROUND SERVICES
THE LOCATIONS OF UNDERGROUND SERVICES ARE APPROXIMATE ONLY AND THEIR EXACT POSITION SHOULD BE PROVEN ON SITE. NO GUARANTEE IS GIVEN THAT ALL EXISTING SERVICES ARE SHOWN.

SYMBOL LEGEND		Prop / Prev Stage	
Drains		Prop	Prev Stage
Sewer < 3000		Ex Natural/FS Level	+28.57
Sewer ≥ 3000		FS @ Building Line	+8.28.57
Water (DW)		Top/Toe Batter Level	+TOP28.57
Water (NDW)		Top/Bottom RW Level	+TW28.57 +BW27.57
House Drain		100yr Flood Level	+FL28.57
Property Inlet		Fill Proposed (<0.3m/±0.3m)	
Street Sign		Cut Proposed	
PSM		Asphalt Surface Prop	
Rock Ret Wall		Concrete Surface Prop (Paths/Driveways/Slabs)	
Sleeper Ret Wall		Tree To Be Removed	
Conduits 50mm		Tree To Be Retained with Tree Protection Zone (TPZ)	
Conduits 100mm			
Street Tree without/with Passive Irrigation (Refer Detail)			
Ex Drains			
Ex Water/DW/NDW			
Ex Sewer/Gas			
Ex Elect/Comm			

AMENDMENTS	DATE	REMARKS	CHECKED
C	13-03-25	IRRIGATION PIT TYPE ADDED	BPD
B	18-02-25	IRRIGATION PIT CHAINAGES AMENDED	M.A.
A	29-05-24	ISSUED FOR CONSTRUCTION	M.A.

brees pitt dixon pty. ltd.
land surveyors civil engineers

MELWAY REF. 355 D-4

ELINYA ESTATE STAGE 4
PASSIVE IRRIGATION PLAN

MUNICIPALITY MELTON

1/19 cato street hawthorn east, 3123 telephone 8823 2300 fax no. 8823 2310

REFERENCE 9980 / 4

SHEET 9 OF 9

DATE FEB '23

SCALE AS SHOWN DATUM AHD